

# Peter Walks on Water



**TRUEWAY KIDS**.COM

# Introduction

Jesus' disciples often had to choose between faith and doubt. In Matthew 14:22-36, we read the miracle of Peter walking on water until he took his eyes off Jesus.

Key Points:

- We should never doubt God.
- Jesus is with us in life's storms.
- When we call out to Him, Jesus will save us.



## Lesson Guide

Remind your child that a miracle is an extraordinary event. Some things people call things miracles that are just unlikely to happen, but Jesus performed acts that were impossible to happen.

If it's safe to do so, plan a barefoot walk that crosses several surfaces. As you walk on each surface, talk about how it feels. Tiles are cold and hard. Carpet is warm and soft. Cement is hard. Mud is sticky. Grass, sand, wood Etc. Set up a paddling pool or small bowl and have them walk through the water. Focus on how they walk IN the water and NOT ON the water. Explain that it is impossible. Peter was able to walk on water because Jesus allowed him to do so.

Ask the child what doubt means. Explain that doubt is to question and disbelieve. It is good to doubt some things people say, but we should never doubt God. As long as Peter was trusting in Jesus, he could walk on water. What happened when he doubted? He sank.

Fill two clear glasses with water. Stir three tablespoons salt into one of the glasses. Label the salted water "faith" and the plain water "doubt". Next, draw a face on a fresh egg to use for this activity. Gently lower the egg into the "doubt" water and watch it sink. Next, drop the egg in the "faith" water. The egg will float. Review the story showing Peter floated (faith glass) and then sank (doubt glass). Think of times where we face a faith or doubt choice. Allow your child to place the egg in the "faith" or "doubt" glass according to the way they would act.

Talk about fear. Fear is often a friend of doubt. Peter grew afraid, doubted, and sank because he lost his focus on Jesus. Draw some pictures representing fears onto note cards, e.g., snakes, spiders, dark, etc. Ask your child to close their eyes and arrange the notecards into the shape of a heart. When they open them again, ask them what they see. If they point to their fears, help them see the heart. Point out that if people focus on the wrong thing, they miss the bigger picture, which is the heart representing how much you love them.

What did Peter do when he was sinking? He called out and asked Jesus to save him. Remind your children that we, too, need to be saved. We might not need Jesus to pull us out of the water, but we need Him to save us from our sins. All we need to do is repent and cry out to Him, as Peter did.

Jesus always hears us when we pray.

Thank God that He is the God of the impossible. Ask Him to help you have faith in Him and never doubt.



Peter cried out, "Lord, save me."

Jesus caught Peter and asked, "Why did you doubt?"

They climbed back into the boat, and the storm stopped.

Everyone in the boat worshipped Jesus, saying, "Truly you are the Son of God."

Peter learned He could always trust Jesus.



## Peter walks on Water

Jesus and his disciples had been busy preaching to crowds and performing miracles.

Jesus wanted some time alone so that He could pray.

He told his disciples to get in the boat and cross the Sea of Galilee ahead of Him.



In the middle of the lake, stormy winds began to blow the disciples boat, and the waves grew high.

Then, all of a sudden, they saw something walking towards them.

The disciples were scared. But then they heard a voice, "Take courage! It is I. Don't be afraid."

Peter couldn't believe his ears. It was Jesus. He told Jesus to call Him to come on the water.



Jesus said, "COME."

Peter got out of the boat and walked toward Jesus on the water.

But then He remembered. People can't walk on water.

He saw the storm and began to panic.

He took his eyes off Jesus and began to sink.

# Games and Activities

## Make a “Storm in a Bottle”

Fill a small plastic bottle with water until it reaches around 3/4 full. Add a few drops of dish liquid and a few pinches of glitter. (You could also add a few drops of food coloring).

Put the cap on tightly and turn the bottle upside down and hold it by the neck.

Quickly spin the bottle in a circular motion. When you stop and look inside, you’ll see a mini tornado forming in the water.

(You might need to try it a few times before you get it working properly.)



## Play in puddles

Puddles have magnetic effect on children. You will have no trouble encouraging them to take part in this activity.

Allow your child to play and have fun. Ask them what kind of jump makes the biggest splash? Challenge them to splash or kick all the water out of the puddle? Ask them what happened if they stir the puddle with their foot or hand. Point out that the water always moved for them.

## Trust Fall or Jump

Ask your child to jump into your arms. Hopefully they will do it with pleasure. To take it a step further, ask them to look in the other direction and to fall backwards and allow you to catch them.

Share it’s easier to trust when you see the person.

Remind your child that they can always trust God. He has the power to always look after them.



# Finish the pictures



Stormy



Sunny



Rainy

# Count the raindrops



Color the object in the center

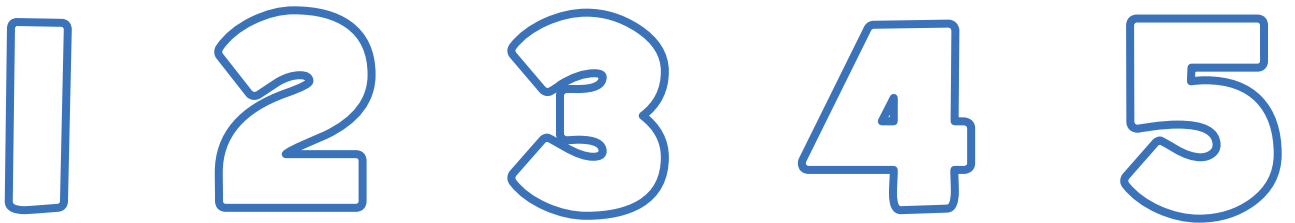
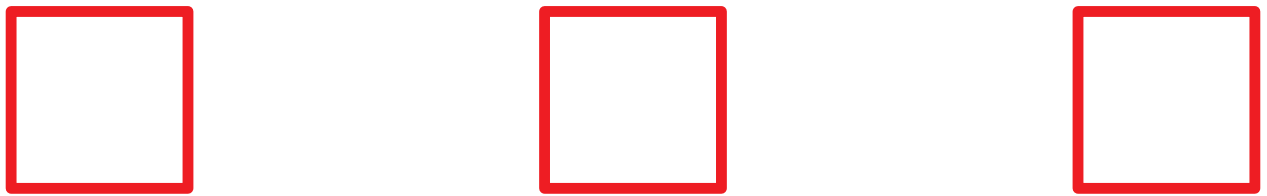
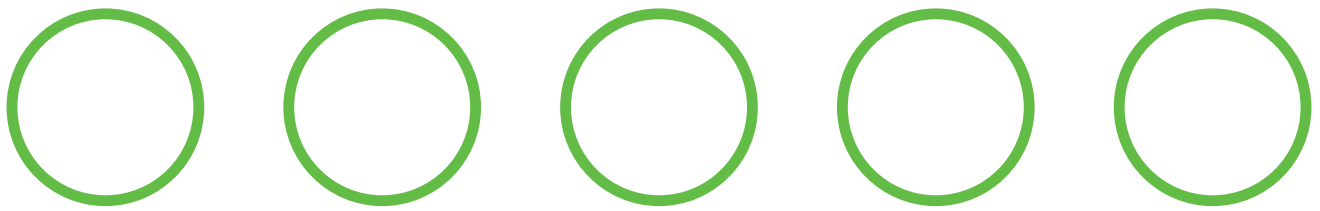

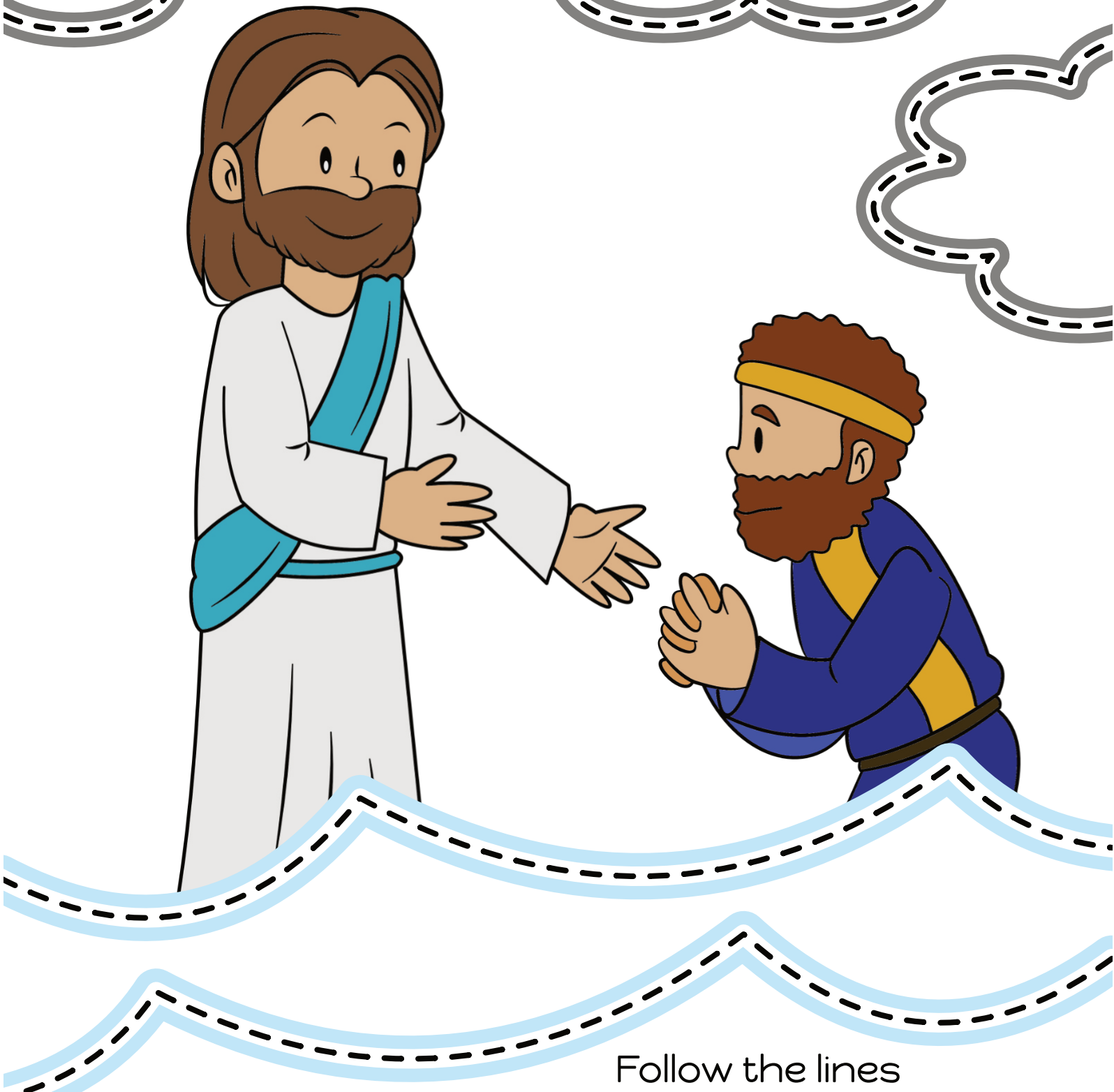

Follow the lines

# Craft - Peter walks on Water

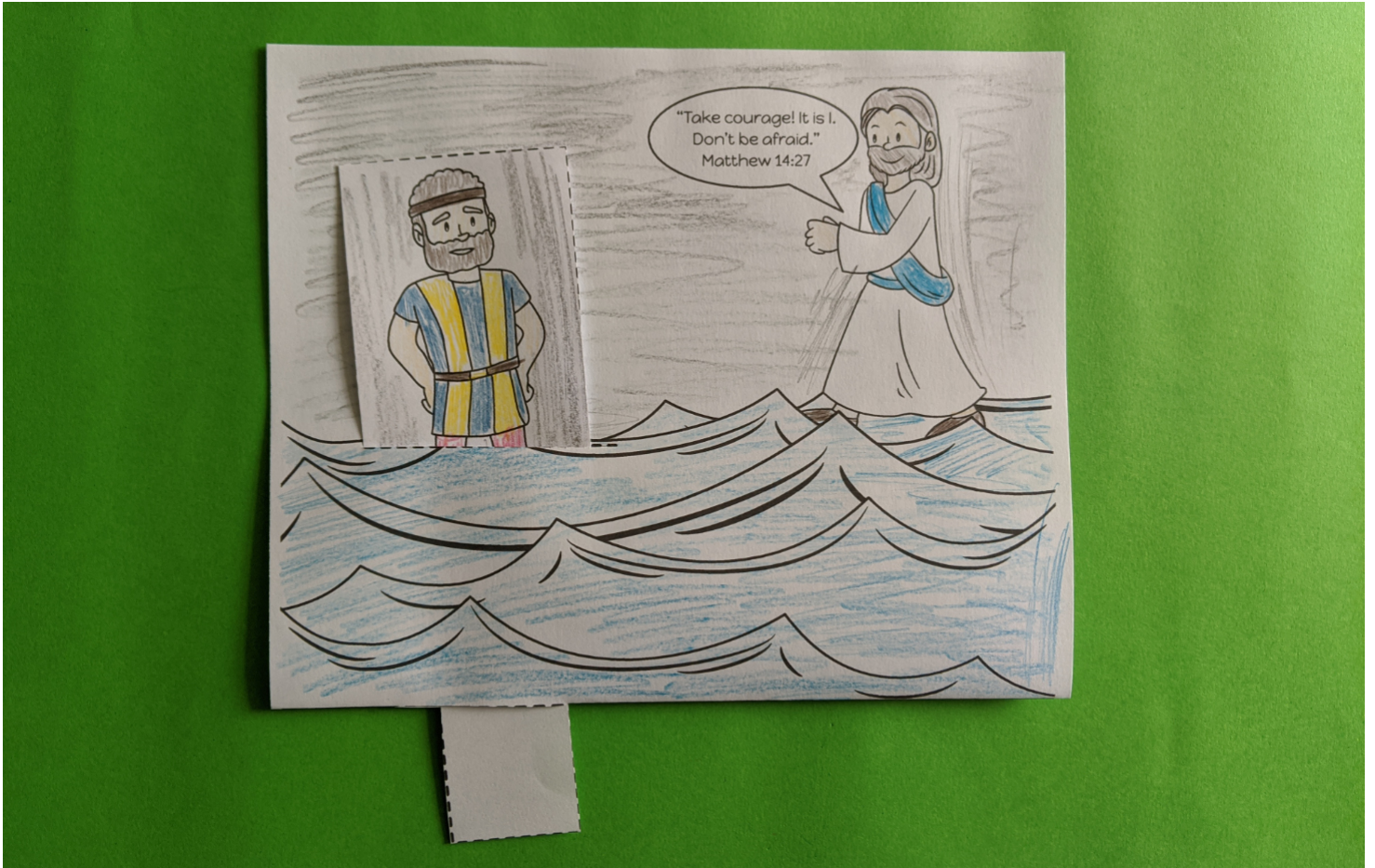

## What you need

Template page,  
Colored pencils,  
Scissors.

## What to do

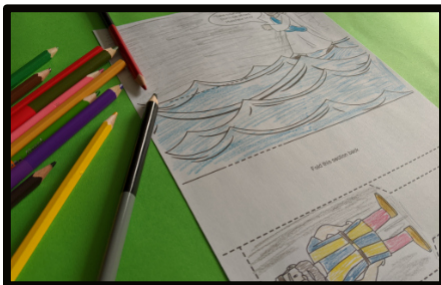

Color the template page.

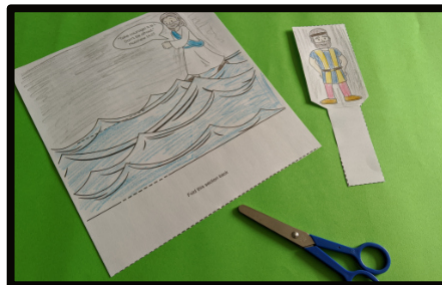

Cut along dotted lines.

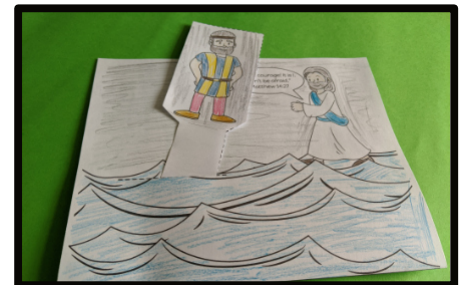

Fold sea section.  
Slide Peter through slots.

“Take courage! It is I.  
Don't be afraid.”  
Matthew 14:27

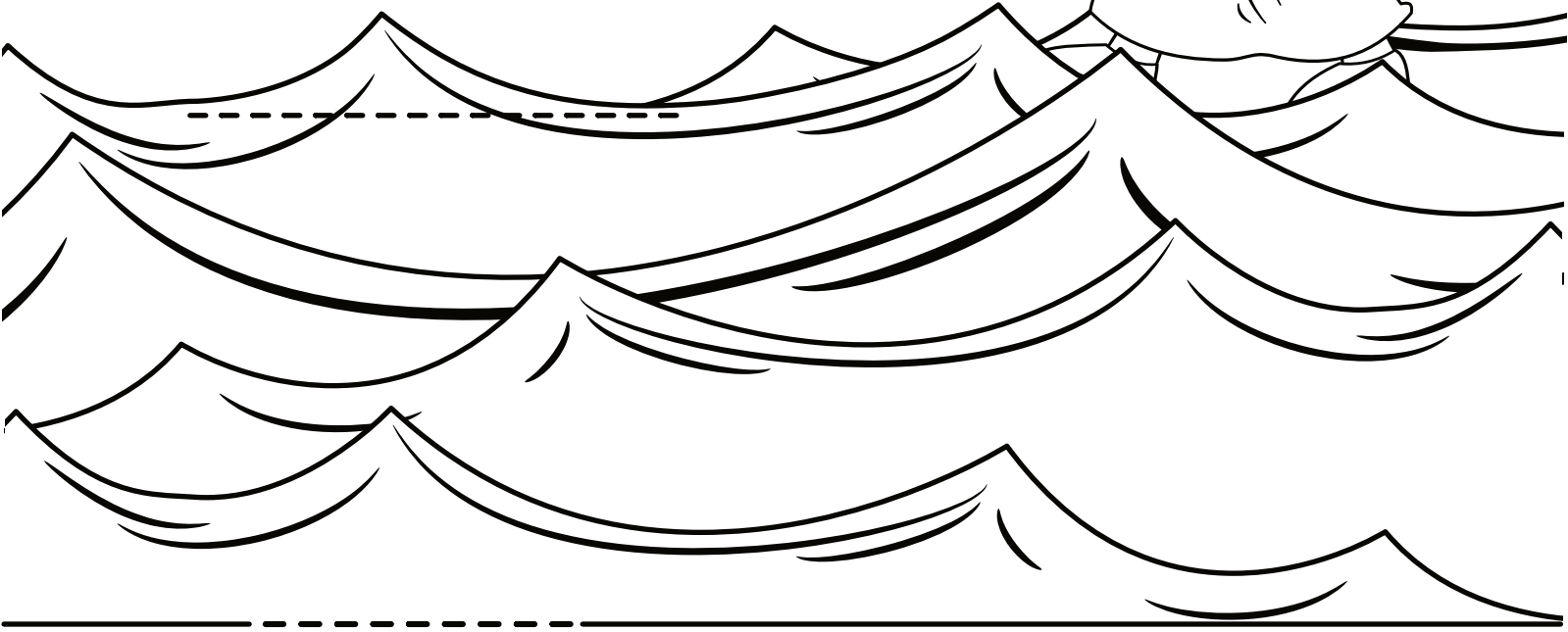

Fold this section back

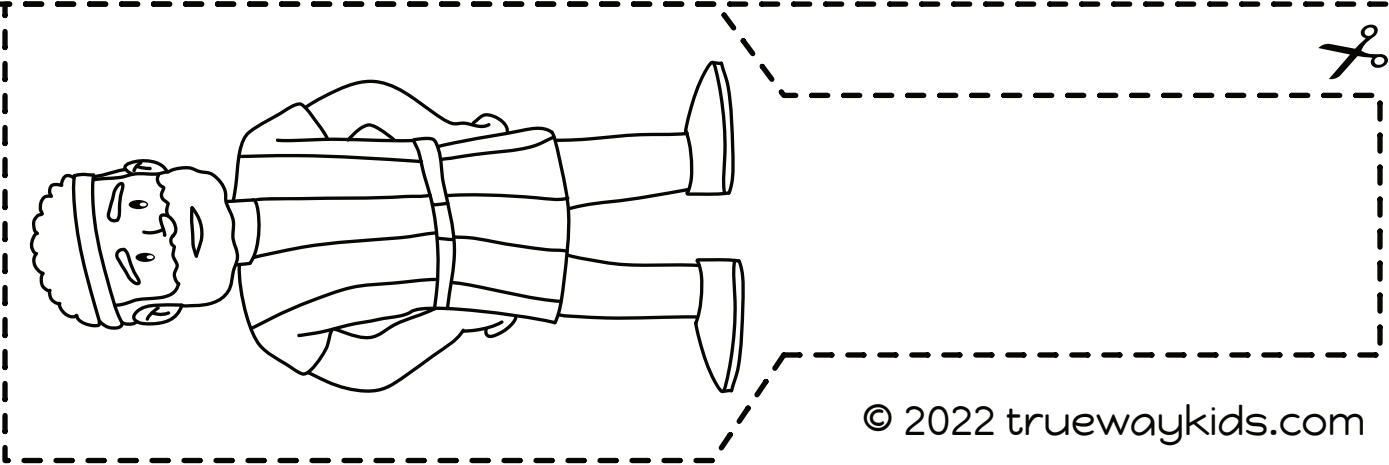

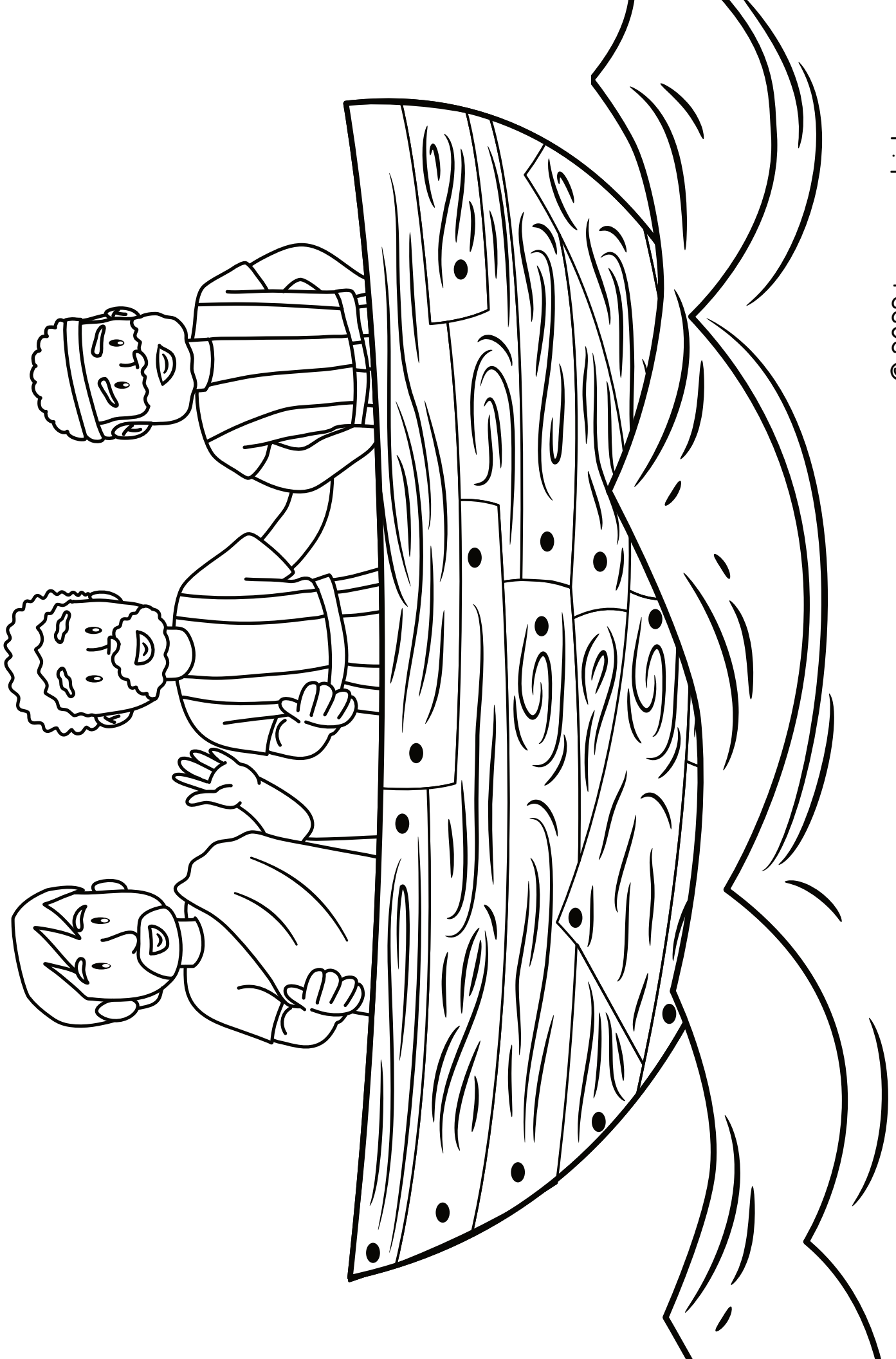

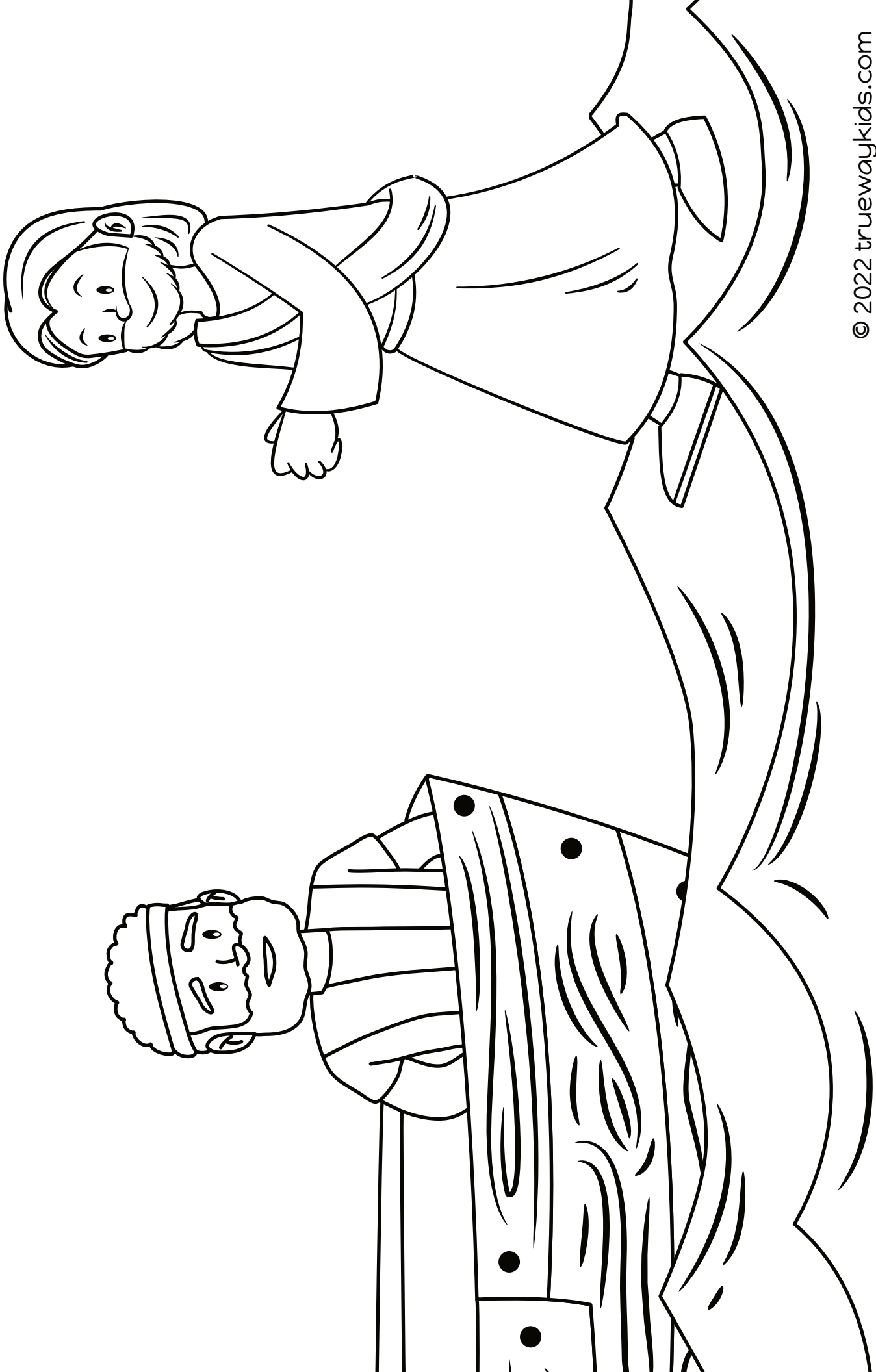

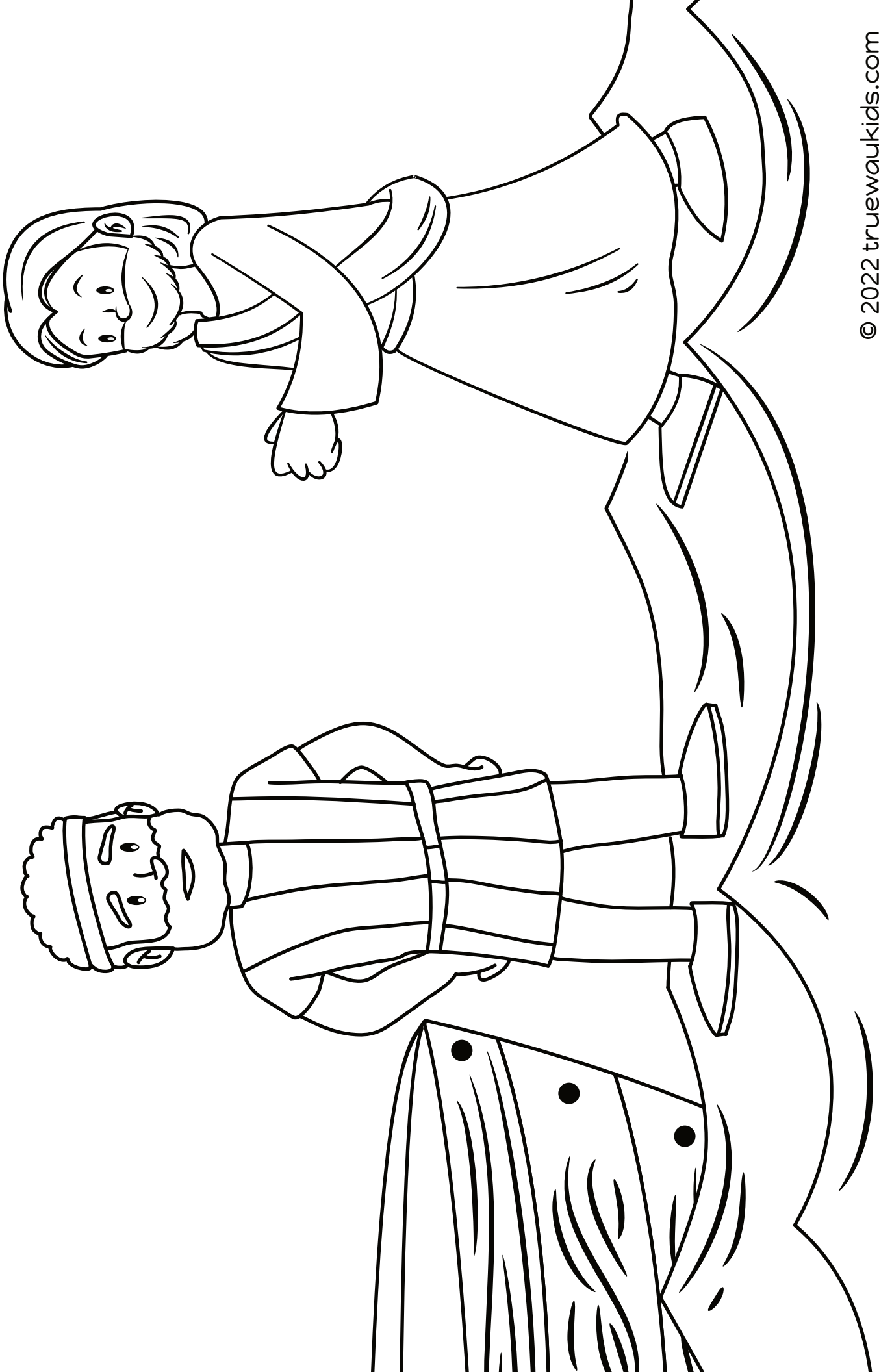



# Worship Time

Recommend worship songs. Not produced by Trueway Kids. YouTube Videos to be used for personal use only.

Faith is just believing song

<https://youtu.be/6Ub-TdbZRXA>

Fixin' My Eyes on You

<https://youtu.be/P0KPmF4Bm2k>

Trust in the Lord

<https://youtu.be/9u8oqITxUJ4>



## Prayer

Thank God that He will never leave you in the storm.

Ask Him to help you put your faith and trust in Him.

## Next Week

The Great Commission  
(Matthew 28:16-20)

If you haven't already done so, sign up to receive future lesson by email.  
[truewaykids.com/subscribe/](https://truewaykids.com/subscribe/)

